

# Express 250

DC Fast Charging Station

## Site Preparation Guide



**Copyright and trademarks**

©2013-2018 ChargePoint, Inc. All rights reserved. This material is protected by the copyright laws of the United States and other countries. It may not be modified, reproduced or distributed without the prior, express written consent of ChargePoint, Inc. CHARGEPOINT is a U.S. and European Union registered trademark and service mark of ChargePoint, Inc. and cannot be used without the prior written consent of ChargePoint.

**No accuracy guarantee**

Commercially reasonable efforts were made to ensure that the specifications and other information in this manual are accurate and complete at the time of its publication. However, the specifications and other information in this manual are subject to change at any time without prior notice.

**Warranty information and disclaimer**

The Warranty you received with your Charging Station is subject to certain exceptions and exclusions. For example, your use of, or modification to, the ChargePoint® Charging Station in a manner in which the ChargePoint® Charging Station is not intended to be used or modified will void the limited warranty. You should review your warranty and become familiar with the terms thereof. Other than any such limited warranty, the ChargePoint products are provided "AS IS," and ChargePoint, Inc. and its distributors expressly disclaim all implied warranties, including any warranty of design, merchantability, fitness for a particular purposes and non-infringement, to the maximum extent permitted by law.

**Limitation of liability**

CHARGEPOINT IS NOT LIABLE FOR ANY INDIRECT, INCIDENTAL, SPECIAL, PUNITIVE OR CONSEQUENTIAL DAMAGES, INCLUDING WITHOUT LIMITATION LOST PROFITS, LOST BUSINESS, LOST DATA, LOSS OF USE, OR COST OF COVER INCURRED BY YOU ARISING OUT OF OR RELATED TO YOUR PURCHASE OR USE OF, OR INABILITY TO USE, THE CHARGING STATION, UNDER ANY THEORY OF LIABILITY, WHETHER IN AN ACTION IN CONTRACT, STRICT LIABILITY, TORT (INCLUDING NEGLIGENCE) OR OTHER LEGAL OR EQUITABLE THEORY, EVEN IF CHARGEPOINT KNEW OR SHOULD HAVE KNOWN OF THE POSSIBILITY OF SUCH DAMAGES. IN ANY EVENT, THE CUMULATIVE LIABILITY OF CHARGEPOINT FOR ALL CLAIMS WHATSOEVER RELATED TO THE CHARGING STATION WILL NOT EXCEED THE PRICE YOU PAID FOR THE CHARGING STATION. THE LIMITATIONS SET FORTH HEREIN ARE INTENDED TO LIMIT THE LIABILITY OF CHARGEPOINT AND SHALL APPLY NOTWITHSTANDING ANY FAILURE OF ESSENTIAL PURPOSE OF ANY LIMITED REMEDY.

**ChargePoint, Inc.**  
254 East Hacienda Avenue  
Campbell, CA 95008 USA

**US and Canada: +1.877.850.4562**

**support@chargepoint.com**

# Contents

<b>1</b>	<b>Introduction</b> .....	<b>1</b>
	Express 250 Overview .....	1
	Before You Begin .....	2
	The Express 250 Concrete Mounting Template .....	2
	Tools and Materials .....	3
<b>2</b>	<b>Preparing the Mounting Pad</b> .....	<b>5</b>
	Overview of Steps .....	5
	Run the Conduit and Cable .....	5
	Assemble the Mounting Template .....	6
	Install the Mounting Template .....	8
	Mounting Specifications .....	9
	AC Conduit .....	10
	AC and DC Conduit .....	11
	Example Photo - Site Preparation Complete .....	12
	<b>Appendix A: Express 250 Specifications</b> .....	<b>15</b>



# Introduction 1

This document describes how to prepare a project site for the ChargePoint Express 250 DC fast charging station. Read this section to familiarize yourself with the Express 250 and ensure that you have all the components, tools, and materials needed to prepare a concrete mounting pad for the Express 250.

**!** **Important:** Always check local codes or consult an engineer to ensure that the site is prepared in compliance with all applicable codes.

## Express 250 Overview

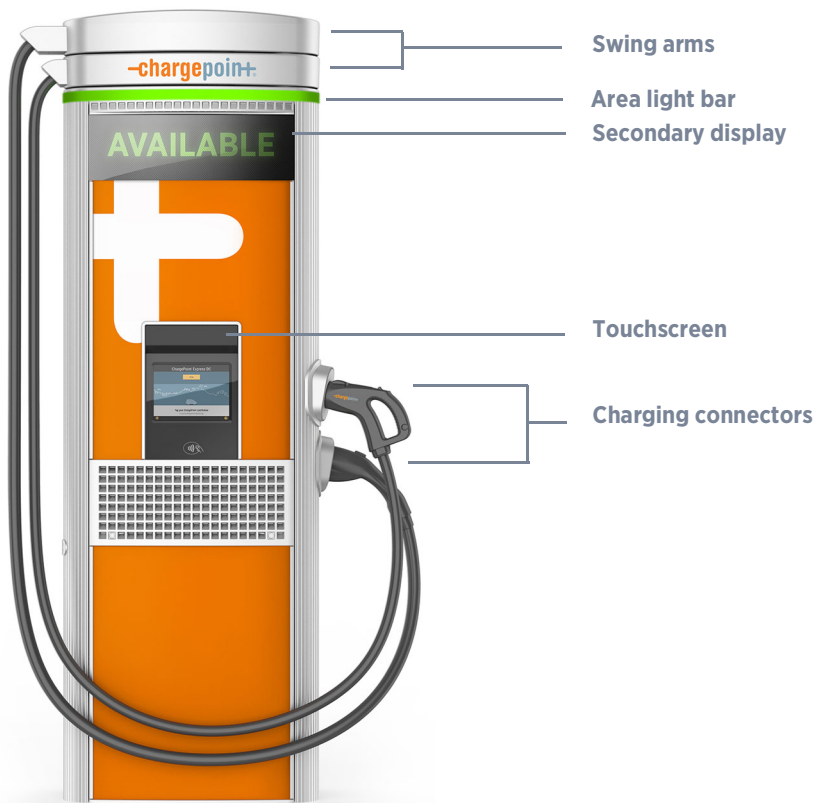

## Before You Begin

- Ensure that the cellular coverage at the installation site is consistently strong. The Express 250 communicates with ChargePoint using the cellular network. A consistently strong cellular signal is needed before installers can activate the station. Use a cellular signal detection device (such as a Squid™) to ensure the signal is -70 dBm or better. If the signal is below -85 dBm, install repeaters to boost the strength of the cellular signals. Repeaters are often required when installing the Express 250 in an underground garage or enclosed parking structure.
- Check that the installation location is equipped with service wiring that supports the Express 250's power requirements. See [Electrical Input on page 15](#).
- Ensure that a grounding conductor that complies with local codes is properly grounded to earth at the service equipment or, when supplied by a separate system, at the supply transformer.



---

**Important:** The Express 250 charging station is tested to IEC 61000-4-5, Level 5 (6 kV @ 3000A) standards. In geographic areas that experience frequent thunder storms, a supplemental surge protection breaker must be installed at the service panel.

---

- Install a disconnect switch installed per NEC Article 625 Electric Vehicle Charging and Supply Equipment Systems.

## The Express 250 Concrete Mounting Template

Preparing the site requires running conduit and building a concrete mounting pad onto which to install the Express 250. To build the mounting pad, you will need the ChargePoint Express 250 Concrete Mounting Template (CPE250-CMT). The Concrete Mounting Template provides correctly-aligned mounting bolts and conduit openings to ensure the Express 250 can be easily positioned and mounted. The Concrete Mounting Template, available from ChargePoint, includes:

- 5/8-11 thread, 12 in long threaded mounting bolts with plastic caps on one end (x6)
- 5/8-11 nuts\* (x24)
- 5/8-11 washers\* (x24)
- Printed specification detailing how to position an assembled Concrete Mounting Template into the concrete.

\*You will need only 12 of the 5/8-11 nuts and washers when assembling the Concrete Mounting Template. The remaining 12 are needed when securing the Express 250 to the mounting pad as described in the Express 250 Installation Guide.

## Tools and Materials

In addition to the Express 250 Concrete Mounting Template (CPE250-CMT) described on the previous page, you will need:

- Digging tools (shovel, spade, etc.)
- Materials to prepare the form for pouring concrete
- Concrete
- Conduit (see [page 5](#))
- 15/16" wrench (x2)
- Pliers to adjust the guide fingers on the conduit opening (if needed)
- Level

THIS PAGE INTENTIONALLY LEFT BLANK



# Preparing the Mounting Pad 2

Follow the instructions in this section to prepare the mounting pad.

## Overview of Steps

- [Run the Conduit and Cable \(page 5\)](#)
- [Assemble the Mounting Template \(page 6\)](#)
- [Install the Mounting Template \(page 8\)](#)

## Run the Conduit and Cable

The Express 250 accommodates service wiring installed underground and run through conduit in compliance with local electrical codes. Consult local codes or a project engineer to determine the grade, quality, and size of the conduit. The CPE250-CMT accommodates service wiring through the flare, conduit, or locally appropriate wiring method.



---

**Important:** The terminal block on the Express 250 accepts 2 AWG wires only. If using a larger gauge wire to accommodate a long run, reduce the wire size at the disconnect.

---

The outer diameter of conduit must not exceed the following:

- AC Conduit 2"
- DC Conduit 3"
- Shunt Trip Conduit 3/4"
- Data Conduit 3/4"

Mounting specifications are provided on [page 9](#).

## Assemble the Mounting Template

Before pouring concrete, you must assemble and position the mounting template. A top-down view, and an assembled template, is shown below.

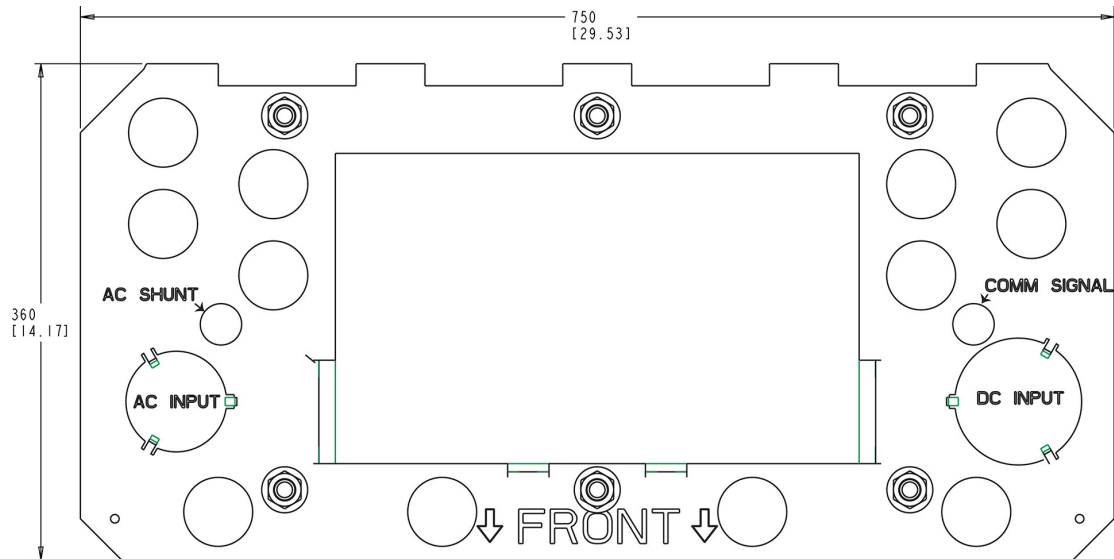

As shown, AC conduit enters the conduit opening on the left-hand side. The conduit on the right-hand side is used for DC conduit.

Follow the steps on the following pages to assemble the mounting template.

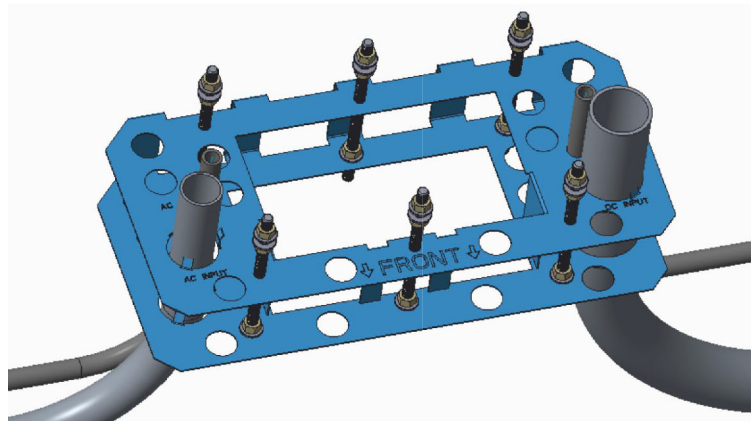

**Step 1** Hold a mounting bolt by its plastic cap and insert the bare end into a bolt hole in the top plate of the template.

**Step 2** Before inserting the bolt through the bottom plate of the template, thread a nut onto the bolt and add a washer (as shown).

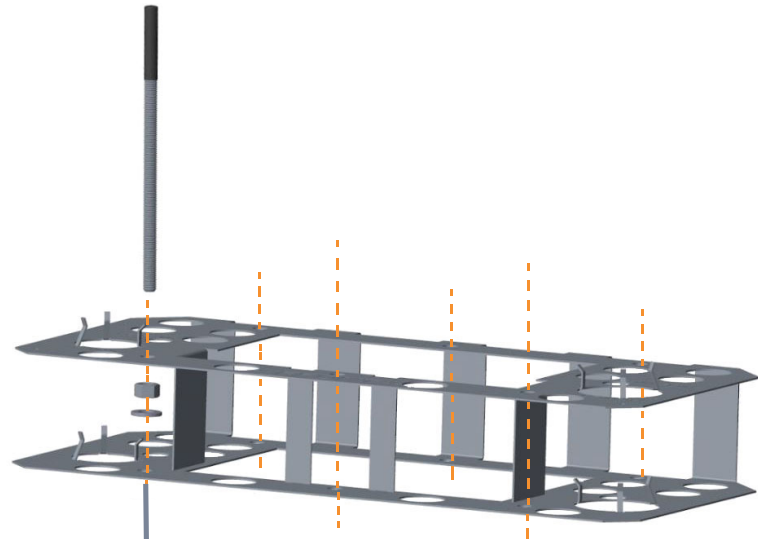

Add a nut and washer before inserting the bolt through the bottom plate of the template

**Step 3** Ensure the plastic cap is pressed fully down on the bolt. Then, holding the bottom nut and washer flush against the top surface of the bottom plate, thread the bolt onto the nut until the distance between the bottom of the plastic cap and the surface of the top plate is 2".

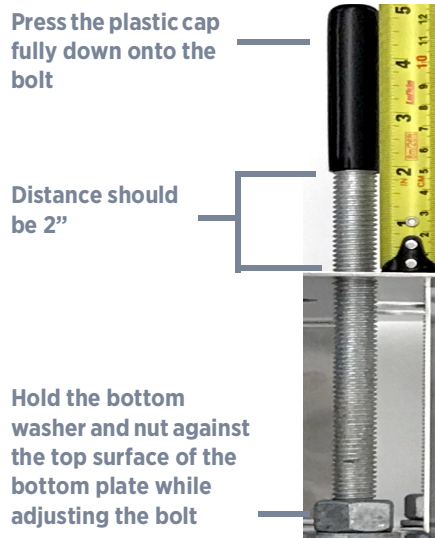

**Step 4** Repeat Steps 1 to 3 for the remaining five bolts.

**Step 5** Secure a second washer and nut onto the bottom of each bolt until flush with the bottom surface of the bottom plate. Tighten each nut to 50 in-lb.

Secure a washer and nut onto the bottom of each bolt and tighten to 50 in-lb

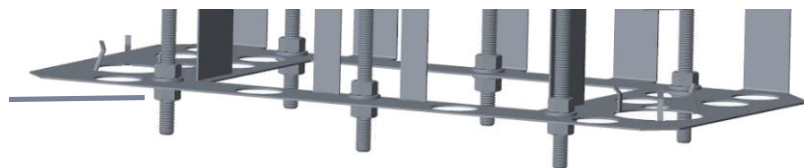

## Install the Mounting Template

Dig an opening to accommodate the wiring conduit and the concrete mounting pad. For details, see [Mounting Specifications on page 9](#).

**Step 1** Trench and excavate an opening for the foundation that meets local codes and requirements.

**Step 2** Build the form for the foundation.



---

**Important:** It is critical that the conduits are positioned properly and plumb. The tolerance where the conduits enter the station is 1/16 in (2 mm).

---

**Step 3** On the template, locate the “FRONT” marking and the conduit guide fingers. The conduit guide fingers face up.

**Step 4** Place the assembled mounting template so that the “FRONT” marking aligns with the location where the front of the station will be placed.

**Step 5** Slide the mounting template over the conduits until the top surface of the template is positioned 2” (51 mm) below where the top surface of the concrete will be when poured. The surface of the concrete must align with the bottom of the plastic caps.

- Carefully press the mounting template down onto the conduit to avoid flexing it.
- Make sure that the conduits are plumb.
- Use a level to check that the mounting template is level from front to back and side to side.



---

**Important:** Before pouring concrete, the template and the conduit must be secured in place to prevent them from rising or floating out of position while the concrete is poured and curing.

---

**Step 6** Pour the concrete.

**Note:** Make sure the concrete surface between the conduits is completely level and free of any irregularities (such as chunks of concrete).

## Mounting Specifications

In the following specifications, measurements are provided in millimeters, with inches provided in brackets.

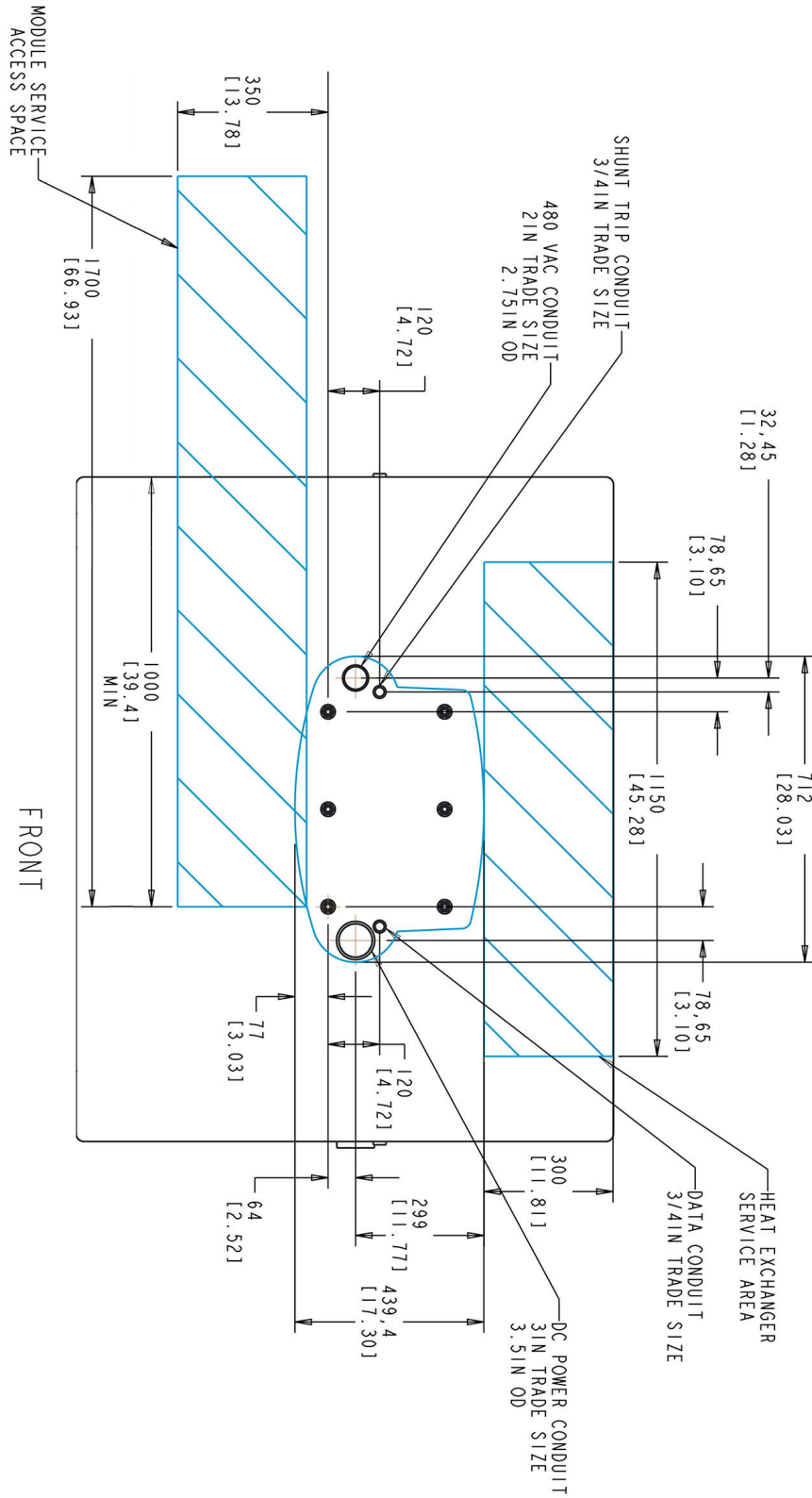

## AC Conduit

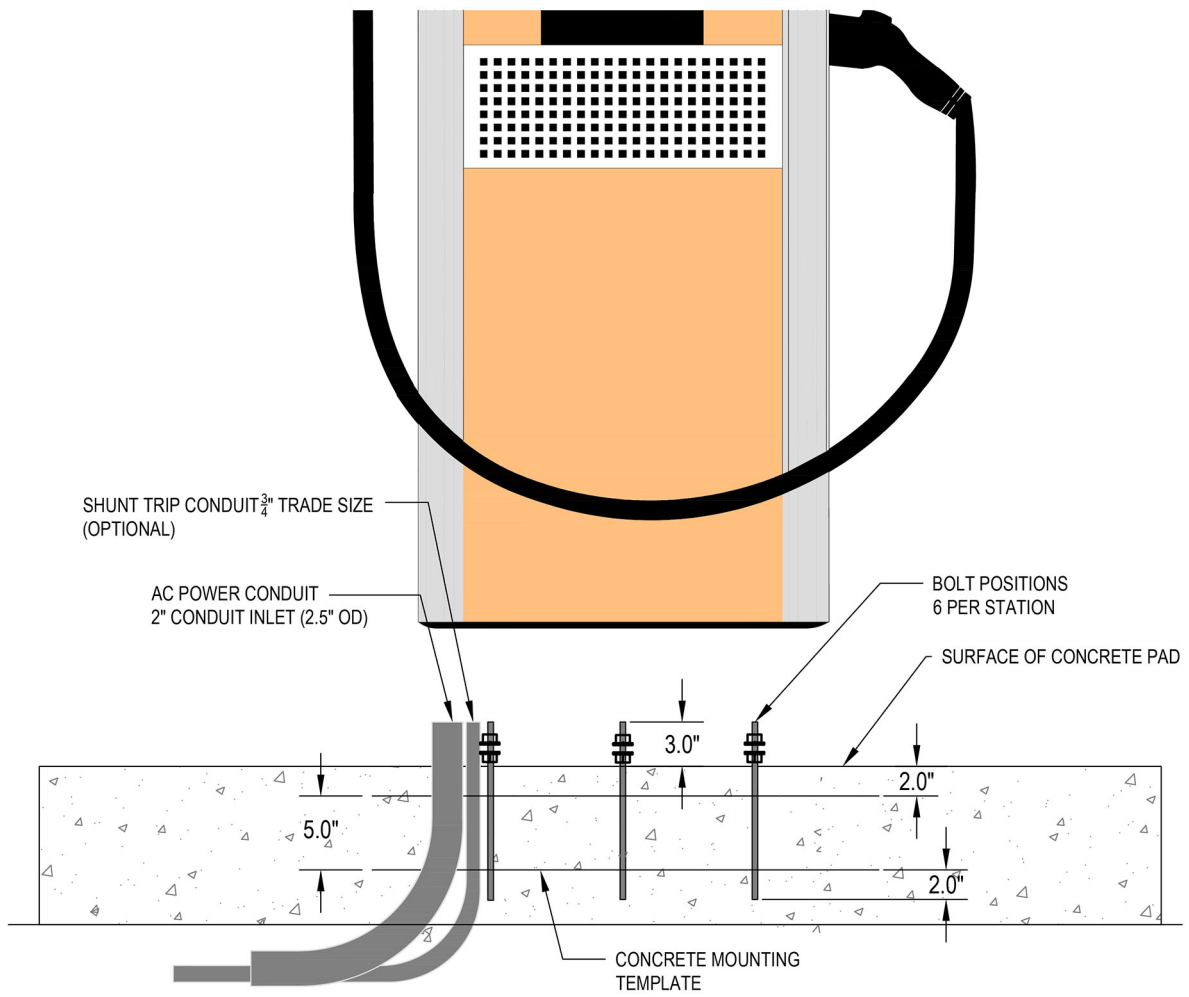

## AC and DC Conduit

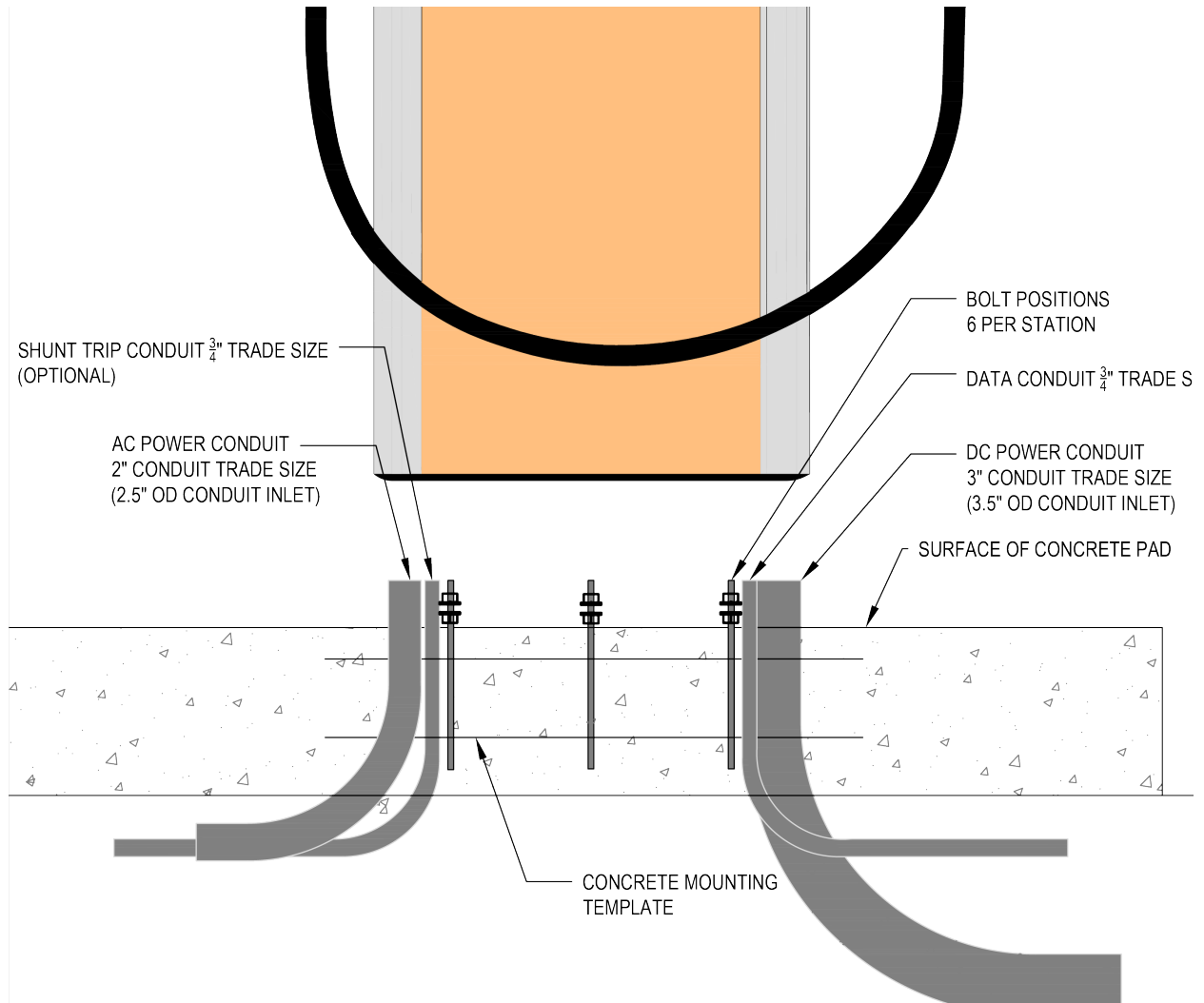

## Example Photo - Site Preparation Complete

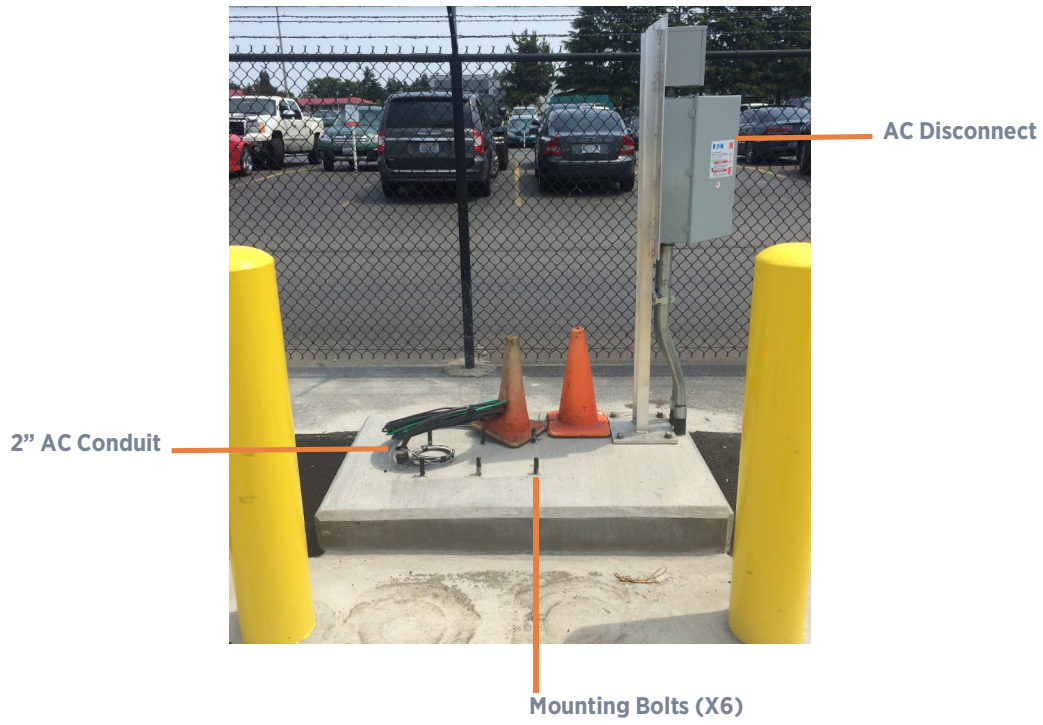



THIS PAGE INTENTIONALLY LEFT BLANK



# Express 250 Specifications **A**

## Power Module

Constant Max Power	31.25 kW
Max Output Current	78A
Dimensions	760 mm x 430 mm x 130 mm (2 ft 6 in x 1 ft 5 in x 5 in)
Weight	38 kg (84 lb)

## Electrical Output

Max Output Power	62.5 kW
Output Voltage, Charging	200-1000 VDC
Max Output Current	156A
Max Modules	2

## Electrical Input

Input Rating	480 (+-10%) VAC, 3-phase, 80A, 60 Hz
Wiring	4 conductors (L1, L2, L3, Ground). Although Neutral is not used in U.S., a terminal connector is provided.
Required Service Panel Breaker	100A (North America - 480V) 125A (EU - 400V)

## Dimensions and Weight

Dimensions	2230 mm x 1120 mm x 420 mm (7 ft 4 in x 3 ft 8 in x 1 ft 4 in)
Weight	250 kg (551 lb) + 41 kg (90 lb) for each power module

## Interfaces

Max Connector Types	Up to 3 different connector types
Supported Connector Types	<ul style="list-style-type: none"> <li>• CCS1 (SAE J1772™ Combo)</li> <li>• CCS2 (IEC 61851-23)</li> <li>• CHAdeMO</li> </ul>
Cord Length	3.8 m (12.5 ft)
Driver Interaction Display	Full-color 10-inch LCD display for driver interaction
Top Display	Full-color 20-inch LED display for notifications
Authentication	<ul style="list-style-type: none"> <li>• RFID: ISO 15693, ISO 14443, NFC</li> <li>• Plug and Charge: IEC 15118-1</li> <li>• Remote: Mobile and in vehicle (if supported by vehicle)</li> </ul>

## Safety and compliance

Safety Compliance	For U.S., complies with UL 2202, UL 2231-1, UL 2231-2 For Europe, complies with IEC 62196, IEC 61851, CE marking
EMC Compliance	U.S.: FCC part 15 Class A EU: EN55011, EN55022 and IEC61000-4

## Environmental requirements

Operational Altitude	<3000 m (<9800 ft)
Operating Temperature	-30° C to 50° C (-22° F to 122° F)
Storage Temperature	-40° C to 50° C (-40° F to 122° F)
Operating Humidity	Up to 95% @ 50° C (122° F) non-condensing
Enclosure Rating	IP44 and NEMA Type 3R

## Grounding requirements

The Express 250 must be connected to a grounded, metal, permanent wiring system. An equipment-grounding conductor must be run with circuit conductors and connected to an equipment-grounding terminal or lead on the Express 250.

A grounding conductor that complies to local codes must be grounded to earth at the service equipment or, when supplied by a separate system, at the supply transformer.

## **SAVE THESE IMPORTANT SAFETY INSTRUCTIONS**

This manual contains important instructions that must be followed during installation of a ChargePoint® DC Fast Charging Station.

### **Grounding instructions**

The ChargePoint® Charging Station must be connected to a grounded, metal, permanent wiring system; or an equipment-grounding conductor is to be run with circuit conductors and connected to the equipment grounding terminal or lead on the Electric Vehicle Supply Equipment (EVSE). Connections to the EVSE shall comply with all applicable codes and ordinances.

### **Safety and compliance**

This document provides instructions to install the ChargePoint® Charging Station and should not be used for any other product. Before installing the ChargePoint® Charging Station, review this manual carefully and consult with a licensed contractor, licensed electrician and trained installation expert to ensure compliance with local building practices, climate conditions, safety standards, and all applicable codes and ordinances.

The ChargePoint® Charging Station should be installed only by a licensed contractor and a licensed electrician and in accordance with all local and national codes and standards. The ChargePoint® Charging Station should be inspected by a qualified installer prior to the initial use. Under no circumstances will compliance with the information in this manual relieve the user of his/her responsibility to comply with all applicable codes or safety standards. This document describes the most commonly-used installation and mounting scenarios. If situations arise in which it is not possible to perform an installation following the procedures provided in this document, contact ChargePoint, Inc. ChargePoint, Inc. is not responsible for any damages that may occur resulting from custom installations that are not described in this document.



254 East Hacienda Avenue  
Campbell, CA 95008 USA  
US toll free: +1.877.850.4562  
[www.chargepoint.com](http://www.chargepoint.com)

Document Part Number 75-001264-01 Rev 1